

OIL FREE VACUUM PUMP

SPARMAX
-The Original 1976



MODEL : TC501

Product Specifications

| Model Number* | Motor Voltage | RPM Motor Type | Power | Net Wt. | |
|---------------|---------------|-------------------|--------|---------|------|
| | | | | lbs. | kg |
| TC501-V | 50/60Hz | (4 or 2 Pole) | 1/8 HP | 8.58 | 3.89 |

V:Vacuum

Features

1. Basic vacuum pump for a variety of laboratory uses.
2. Oil-less and low maintenance
3. Low noise level (under 55 dB).
4. Large rubber feet dampens vibrations and add stability.
5. Easy replacement of moisture trap and filter

Specification

6. Motor Power 1/8 HP
7. Power supply 220V, 50Hz
8. Max Vacuum 650 mm Hg
9. Flow Rate 16 l/min
10. Port Thread 1/8" NPT
11. Net Weight 3.89 kg
12. Easy adjustment of vacuum
13. Vacuum gauge included as standard accessory

**** 1 year warranty ****

Product Performance (TC501-V)

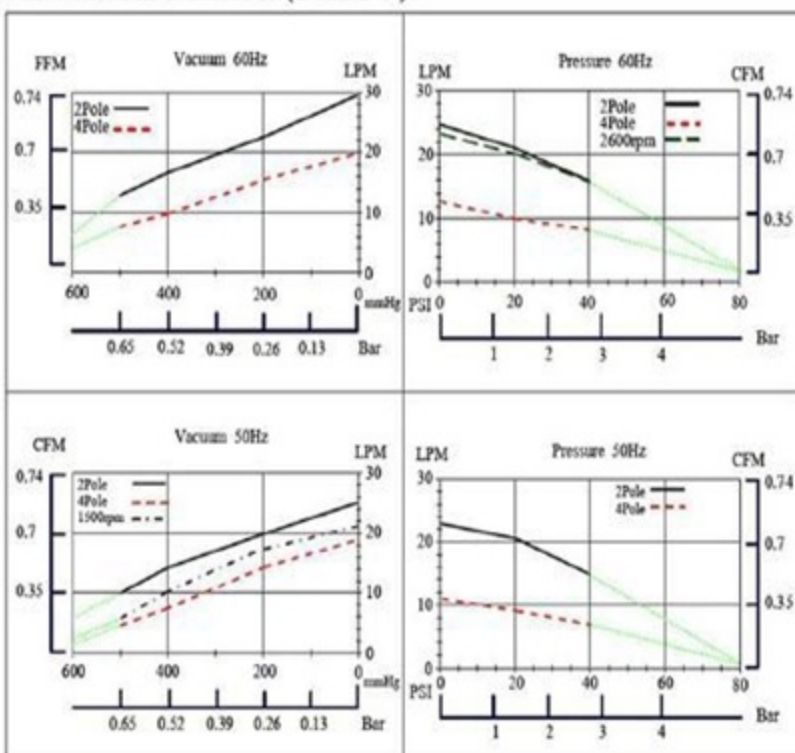

DIAPHRAGM PUMPS

ME 4 AND ME 4C



ME 4 one-stage

.....3.6 m³/h
2.4 cfm
67 l/min

..... < 80 mbar

..... < 60 Torr

ME 4C one-stage

.....3.6 m³/h
2.4 cfm
67 l/min

..... < 80 mbar

..... < 60 Torr

The ME 4 and ME 4C are one-stage diaphragm pumps. They have a higher pumping speed than the ME 2 and ME 2C respectively and therefore offer a wider field of applications. Optimised kinetics for minimum wear of the diaphragm result in high reliability, low scuffing, long life and low noise levels.



ME 4C

SPECIAL ADVANTAGES

- Continuous, oil-free pumping of gases and vapours
- Selected chemically resistant materials (ME 4C)
- No water consumption, no waste water
- Long lifetime, easy-to-change diaphragms and valves
- Low noise level
- Compact design

The choice between the two basic designs depends on the application:

ME 4 "Aluminium"

Gas-contacting parts made of e.g. aluminium, FPM and PE. Designed for a multitude of applications involving non-aggressive gases in laboratories and process plants, like vacuum filtration, vacuum degassing and vacuum impregnation.

ME 4C "Chemistry"

All parts coming into contact with gases and vapours are made of chemically resistant fluoroplastics, e.g. PTFE and ETFE. Typical applications are the transfer of aggressive gases and vapours, rotary evaporation, gel drying, etc.



ME 4

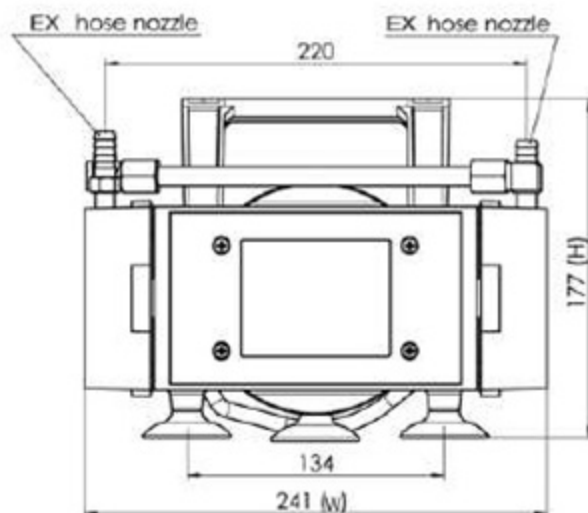

ME 4C

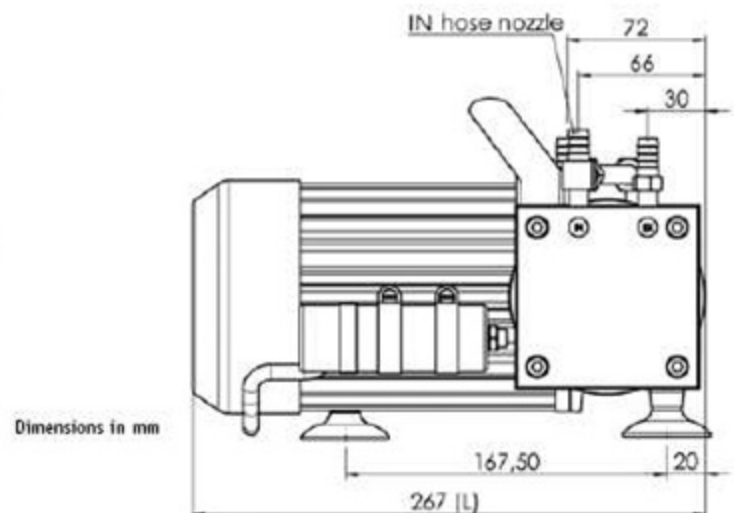

Dimensions in mm